

## Filter chamber KFAA

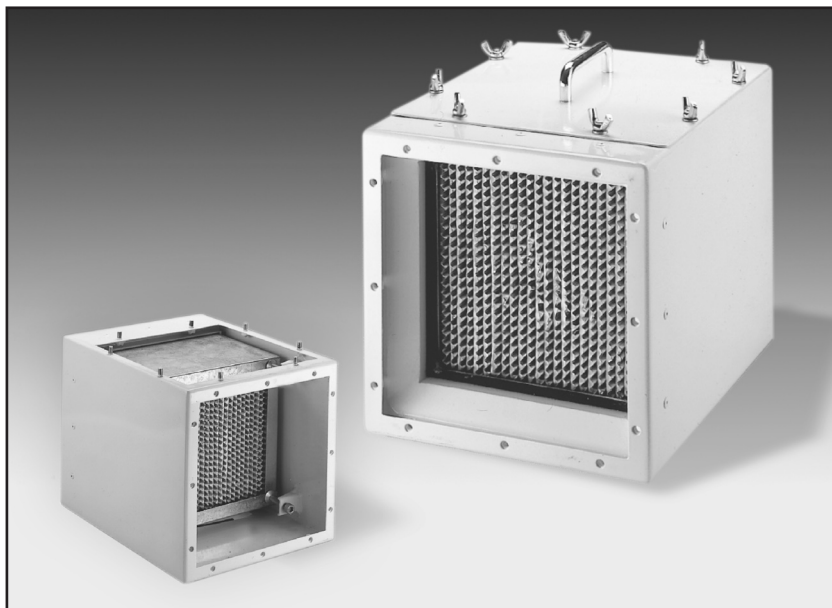

Filter chamber KFAA is used in ventilation ducts and should be installed before diffusers destined for rooms of the high air purity requirement. Chamber includes filter pack of class H13 according to EN 1822-1 norm. There is possibility to deliver filter chamber KFAA equipped with accurate filter pack of class F8 or F9 according to EN 779 norm.

Revision with rubber gasket ensures the high device leaking tightness and enables to replace a filter pack easily and quickly. In the housing of filter chamber there are placed two measurement pipes in order to measure the overpressure.

One of them (red colour marked) shows the total pressure drop on a filter pack and the moment of filter pack replacement. Second pipe is installed in the profile frame and allows to detect filter pack leakage. Filter chamber KFAA is made of painted steel sheet. It can be also additionally equipped with a pressure control showing the necessity of filter pack replacement.

### Product facts

#### Filter chamber KFAA

Available in 7 sizes

Can be equipped with 3 filter lengths

Available in 4 filter classes

#### Product code example:

Filter chamber KFAA-40-63-13-15-1  
Chamber for installation in duct size 400x630 mm, equipped with filter class H13 of 150mm depth, painted RAL 9010 colour.

AIRTREND Ltd  
Predstavništvo u Beogradu  
Kumanovska 14, 11000 Beograd  
Tel: 011/3836886, 3085740  
Faks: 011/3444113  
e-mail: gobrid@eunet.rs  
web: www.airtrend.rs

# Construction, dimensions

## Filter chamber construction

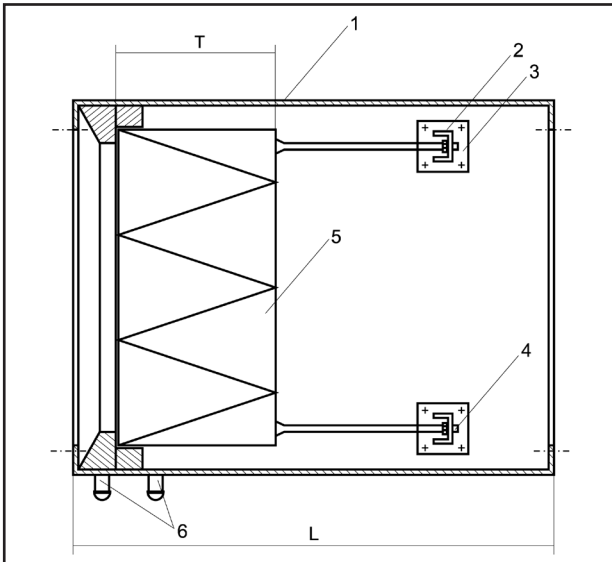

- 1 – housing
- 2 – bracket
- 3 – square washer
- 4 – nut
- 5 – filter pack
- 6 – measurement pipes

## Outside dimensions of filter chamber equipped with filter pack class H13

Type	Filter pack depth (mm)	Filter chamber length L (mm)
KFAA – 80/13	80	250
KFAA – 150/13	150	300
KFAA – 292/13	292	450

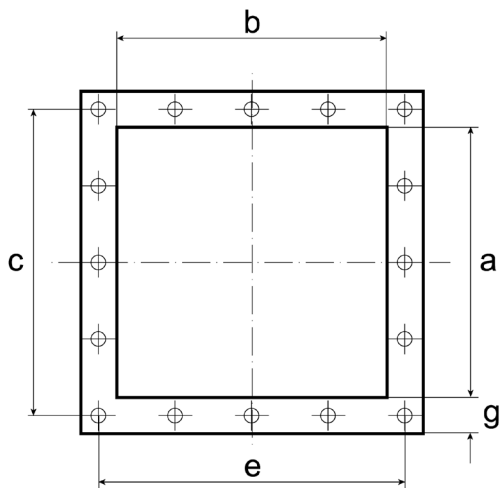

Duct dimensions (mm) a x b	Filter pack outside dimensions (mm)		Chamber dimensions (mm)		
	B	H	c	e	g
250 x 250	202	202	280	280	30
400 x 400	305	305	430	430	30
400 x 630	305	610	430	660	30
500 x 500	405	405	530	530	30
500 x 500	457	457	530	530	30
630 x 630	610	610	660	660	30
630 x 800	610	762	660	830	30

# Pressure drop

Pressure drop on filter chamber KFAA-80/13

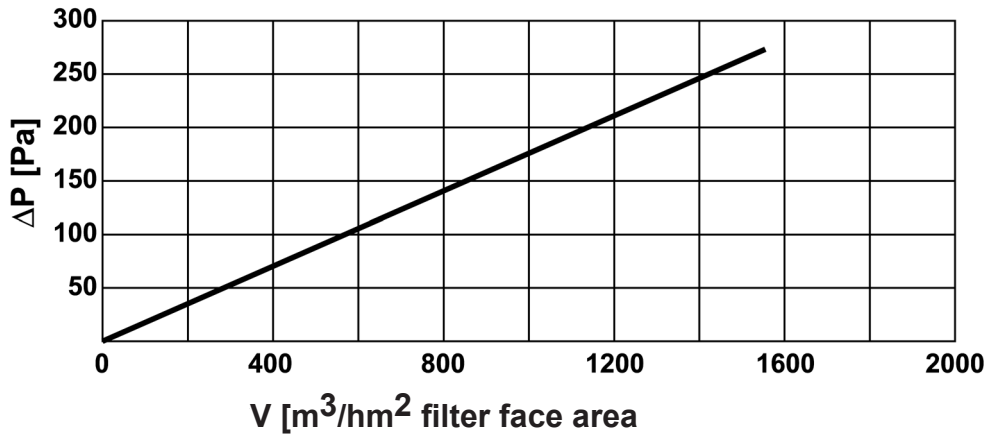

Pressure drop on filter chamber KFAA-150/13

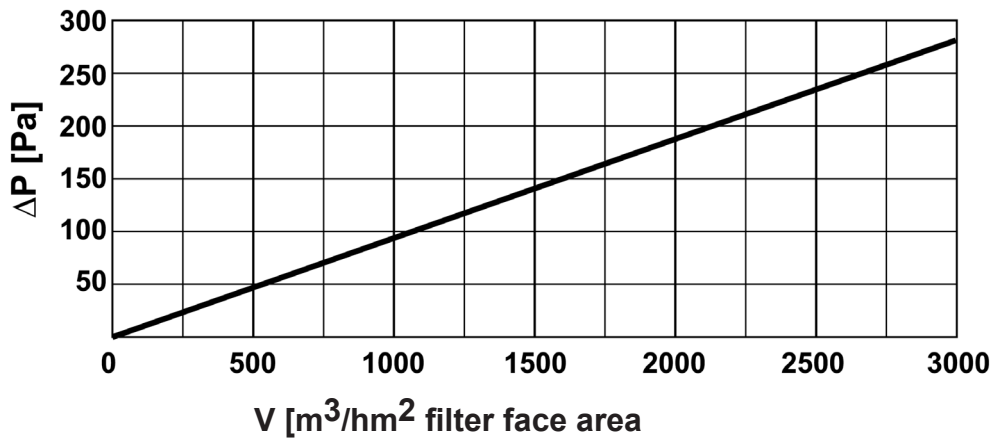

Pressure drop on filter chamber KFAA-292/13

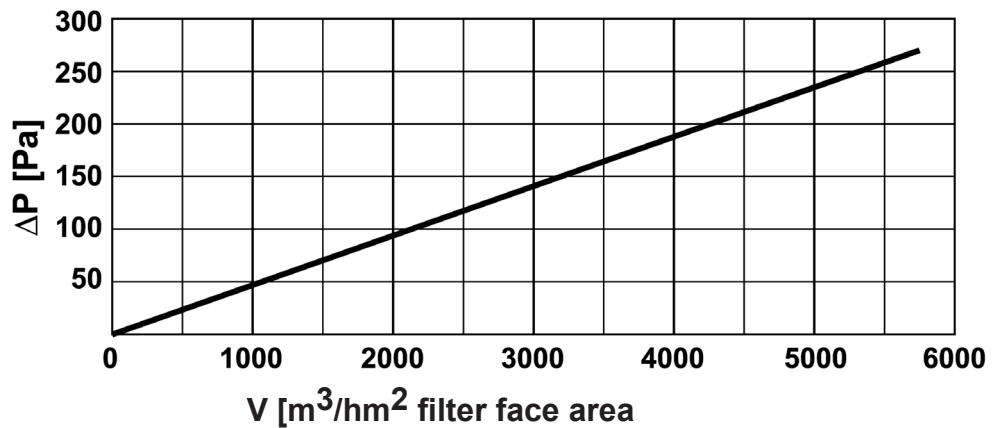

## Pressure drop, dimensions

Maximum pressure drops on chambers indicate the need of filter packs replacement.  
The measurement is obtained by using the pipe red colour marked.

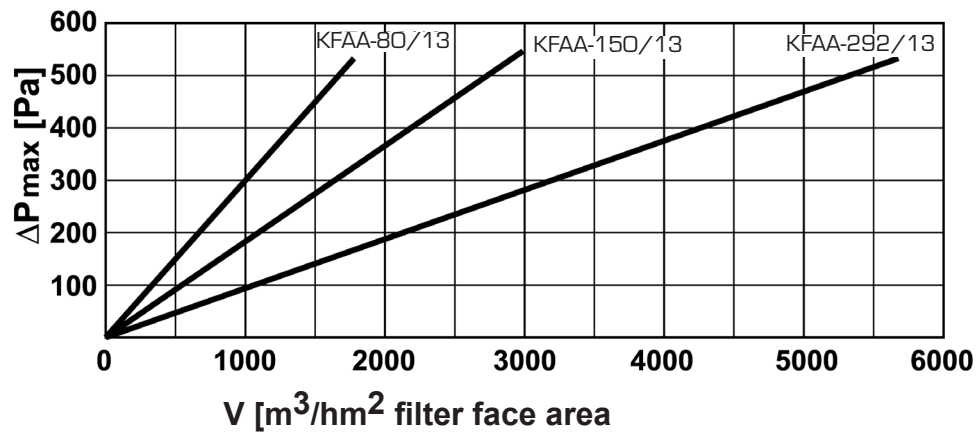

Outside dimensions of filter chamber equipped with filter pack class F8 or F9

Type	Filter pack depth (mm)	Filter chamber length L (mm)
KFAA - 150/8(9)	150	300
KFAA - 292/8(9)	292	450

Duct dimensions (mm) a x b	Filter pack outside dimensions (mm)		Chamber dimensions (mm)		
	B	H	c	e	g
400 x 400	305	305	430	430	30
400 x 630	305	610	430	660	30
500 x 500	405	405	530	530	30
630 x 630	610	610	660	660	30
630 x 800	610	762	660	830	30

# Pressure drop

Pressure drop on filter chamber KFAA-150/8(9)

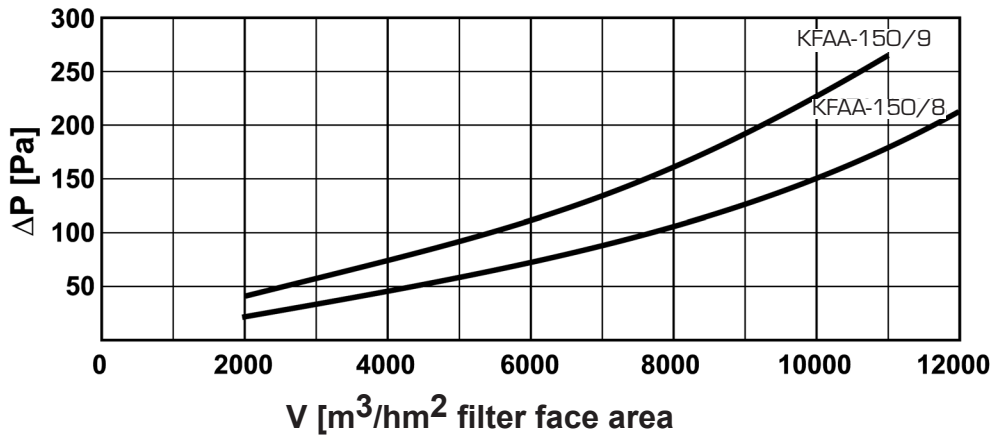

Pressure drop on filter chamber KFAA-292/8(9)

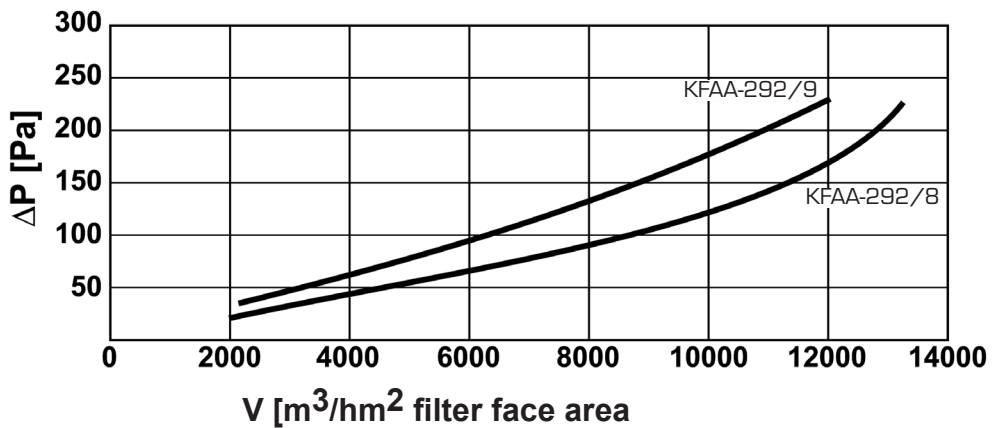

Maximum pressure drops on chambers indicate the need of filter packs replacement. The measurement is obtained by using the pipe red colour marked.

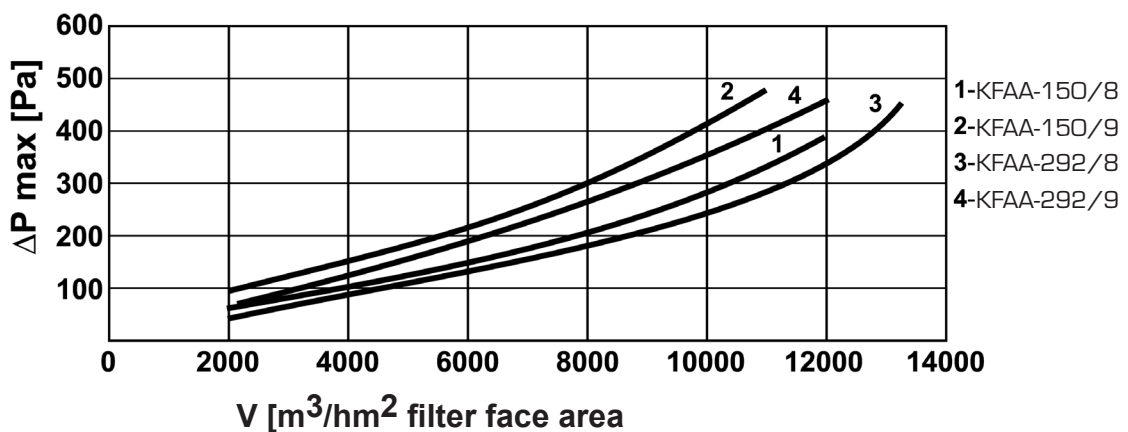

## Descriptive text, product code

### Descriptive text

Filter chamber KFAA for installation in duct manufactured by Fläkt Woods.

### Product code

<b>Filter chamber</b>	<b>KFAA-aa-bb-cc-dd-e</b>
Size (cm) 25-25, 40-40, 40-63, 50-50, 63-63, 63-80	
Filter class 08 = F8 09 = F9 13 = H13 14 = H14	
Filter depth (cm) 08, 15, 29	
Colour 1 = standard RAL 9010 X = any other colour from RAL palette	